

Ø 12-32 mm



SYSTEM **KAN-therm**

Push

Reliability and durability

EN 2015



TECHNOLOGY OF SUCCESS



ISO 9001



About KAN

Innovative water and heating solutions

KAN was established in 1990 and has been implementing state of the art technologies in heating and water distribution solutions ever since.

KAN is a European recognized leader and supplier of state of the art KAN-therm solutions and installations intended for indoor hot and cold tap water installations, central heating and floor heating installations, as well as fire extinguishing and technological installations. Since the beginning of its activity, KAN has been building its leading position on such values as professionalism, innovativeness, quality and development. Today, the company employs over 600 people, a great part of which are specialist engineers responsible for ensuring continuous development of the KAN-therm system, all technological processes applied and customerservice. The qualifications and commitment of our personnel guarantees the highest quality of products manufactured in KAN factories.

Distribution of the KAN-therm system is performed through a network of commercial partners all over Poland, Germany, Russia, Ukraine, Belarus, Ireland, the Czech Republic, Slovakia, Hungary, Romania and in the Baltic States. Our expansion and dynamic development has proven so effective that KAN-therm labeled products are exported to 23 countries, and our distribution network assumes Europe, a great part of Asia, and a part of Africa.

The KAN-therm system is an optimal, complete multipurpose installation system consisting of state of the art, mutually complementary technical solutions for pipe water distribution installations, heating installations, as well as technological and fire extinguishing installations. It is the materialization of a vision of a universal system, the fruit of extensive experience, the passion of KAN's constructors, as well as strict quality control of our materials and final products.



SYSTEM KAN-therm
- special award:
Pearl of the highest quality
and:
Golden Quality International Medal
2015, 2014 i 2013.

TECHNOLOGY OF SUCCESS



Table of contents

3	KAN-therm Push System
4	Advantages
5	Application
6	Pipes
7	Fittings
8	Durability
8	Tools
10	Assembly
10	Highest quality guaranteed
11	Past projects

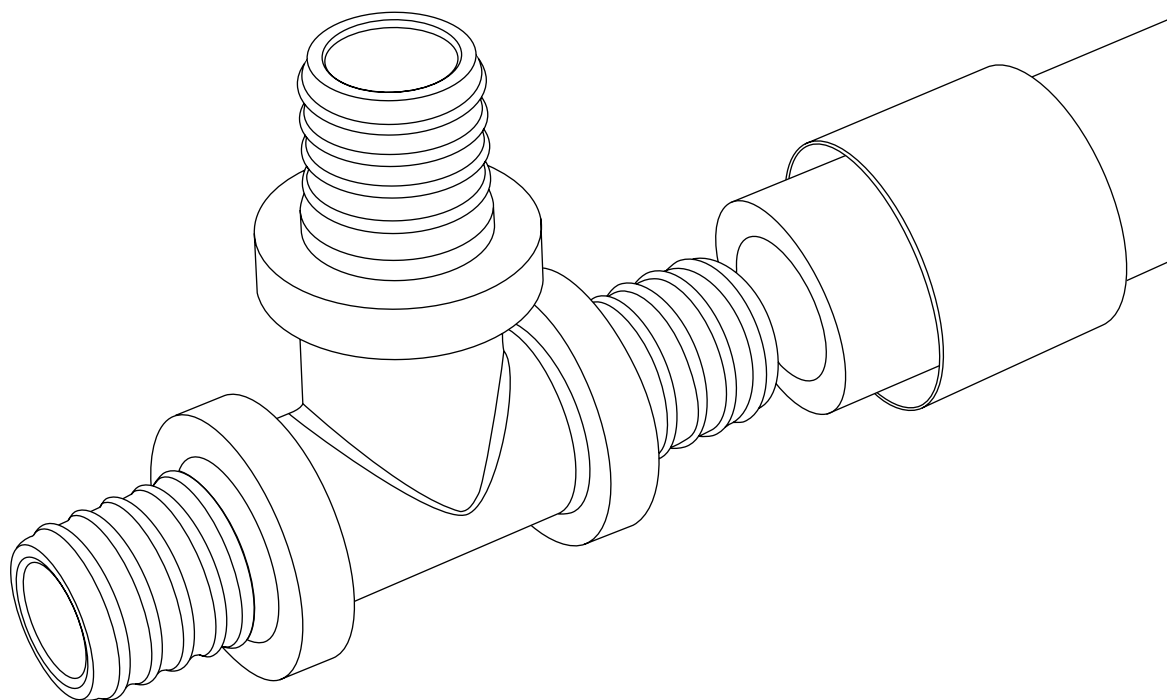

SYSTEM **KAN-therm**

Push

KAN-therm Push is a complete, all-plastic installation system designed for constructing indoor-use heating and potable water installations, utilizing a secure, fast and safe jointing method, based on sliding a brass ring onto the fitting. Its main advantage is its resistance to assembly errors, and a simple jointing system without O-rings.

KAN-therm Push is ideal for new construction projects and renovations of existing, internal central heating, surface heating and cooling (floors and walls), and hot and cold tap water installations.

Due to its material characteristics and range of diameters, the system is particularly recommended for pipe installations in single-family housing. However, it may be also applied in multi-family or public buildings, with equal success.

Advantages

KAN-therm Push offers:

- **More than 20 years of experience** – KAN-therm Push pipes and fittings have been successfully applied on the Polish market and on the Eastern markets since the nineties. It is one of the first modern pipe systems based on Pe-Xc and PE-RT pipes and a modern jointing technology (Push – ring-pressing) on the market. Solid structure, infallibility, easy and quick assembly are the features that gain more and more supporters every year.
- **Reliability** – thanks to our unique solution – KAN-therm Push & Seal™ for self-sealing joints, there is no need to use any O-rings in the fittings.
- **Durability** – tested and certified with the KAN-therm T50™ test, a simulation of 50-years' installation use in a state of the art, international KAN laboratory. Thanks to the use of the latest achievements in the field of pipe system tests, the laboratory was accredited by Western certifying bodies. All system elements are produced according to PN-EN ISO standards and hold applicable approvals and licenses issued by national and foreign certifying bodies.
- **Universal applications** – resistance of all elements to high temperature and pressure makes KAN-therm Push suitable for all types of installations.
- **Compatibility** – fittings may be jointed with PE-Xc and PE-RT pipes with anti-diffusion coating as well as with multilayer Platinum pipes (with an external aluminum coating).
- **Reduction of pressure loss** – special fitting construction allows for minimizing the diameter narrowing phenomenon (the bottleneck effect), which results in reduced pressure loss in the pipe-fitting joint, ensuring optimal flow of the medium through the entire installation.
- **Health and ecology** – materials used to produce system elements are proven in terms of physiological and microbiological inertness in potable water installations, plus they do not alter the chemical composition of potable water - as confirmed by a certificate of the Polish Hygiene Institute - and are therefore neutral for the natural environment and human health
- **Resistance to assembly errors** – universal structure of brass slide-on rings, which does not require any additional structural sealants, as well as simple assembly technology and the application of professional and easy-to-use tools reduce the possibility of making an assembly error to the absolute minimum.
- **Sub-plaster assembly** – the possibility of mounting and covering joints in floor and wall structures (under plaster coats)
- **State of the art technologies in production** – the production process utilizes state of the art, the most effective and, most of all, the safest methods of improving the durability of polyethylene pipes by cross-linking them using the physical "c" method, which stands for bombarding the pipes with a beam of electrons in order to "strengthen" them without the use of chemicals.

Methods of connecting wall-fed or floor-fed VK heaters using KAN-therm Push System elements.



Application



The system is designed for constructing indoor-use heating installations, cooling installations, hot and cold tap water installations in single-family housing (risers and horizontal feeding pipes), multi-family housing (horizontal feeding pipes) and public buildings (horizontal feeding pipes).

PE-Xc and PE-RT pipes may be successfully used for constructing indoor and outdoor surface heating or cooling systems, such as e.g. ice skating rinks, garage driveways, communication tracts, terraces, staircases, etc.

Thanks to the infallibility of the system, resistance to errors in assembly, and, most of all, thanks to the absence of the shape memory phenomenon for polyethylene pipes (the pipe bottleneck or pipe clogging phenomenon under mechanic stress), the system is particularly recommended for installations which may be subject to damage by outside personnel – e.g. being treaded on by other workers at the construction site.

According to PN-EN ISO 22391, PE-RT pipes, and according to PN-EN ISO 15875, PE-Xc pipes operate with the following parameters:

- **heating installations:** $T_{op}/T_{max} = 80^{\circ}\text{C}/90^{\circ}\text{C}$, $P_{op} =$ up to 10 bar
- **tap water installations:** $T_{op}/T_{max} = 60^{\circ}\text{C}/80^{\circ}\text{C}$, $P_{op} =$ up to 10 bar

Due to its properties, the KAN-therm Push System may be also applied in a range of non-standard pipe installations, such as compressed air installations. The condition for admitting the use of KAN-therm Push system in non-standard applications is obtaining positive assessment of KAN's Technical Department.



Pipes

Safety, quality, hygiene

Due to economic and technical aspects, as well as the possibility of optimizing the range of applications, the KAN-therm Push System offers two material configurations of polyethylene pipes:

PE-Xc pipes

PE-Xc plastic pipes are made of polyethylene which, at the last stage of production, undergoes the so-called reinforcing (cross-linking) process. The process utilizes the safest in terms of hygiene (no chemical additives in the production process) and the most effective cross-linking method – type “c”. It is based on subjecting a pre-produced pipe to a “bombarding” with a beam of electrons, which results in altering the molecular structure of polyethylene, and, ultimately, in extending the period of usability of the finished product.

Notice, that in the case of the “c” method, the required level of cross-linking is lower, which means that, with the same degree of cross-linking, pipes produced using this method display higher resistance to pressure and temperature (the process of ageing), compared to pipes cross-linked using the “a” or “b” chemical methods.

Pipe marking	Name of cross-linking method	Required degree of cross-linking according to DIN 16892, EN 12318
PE-Xc	High-density polyethylene cross-linked with a stream of electrons	60%
PE-Xa	High-density polyethylene cross-linked with peroxide	70%
PE-Xb	High-density polyethylene cross-linked with silan	65%

Cross-linking pipes using the physical method, without the addition of any chemical substances is particularly important when using PE-Xc pipes to perform tap water installations, where product hygiene is of the essence.

PE-RT pipes

PE-RT type II pipes in the KAN-therm Push system are produced out of polyethylene octane copolymer, resistant to high temperatures and characterized by perfect mechanic properties.

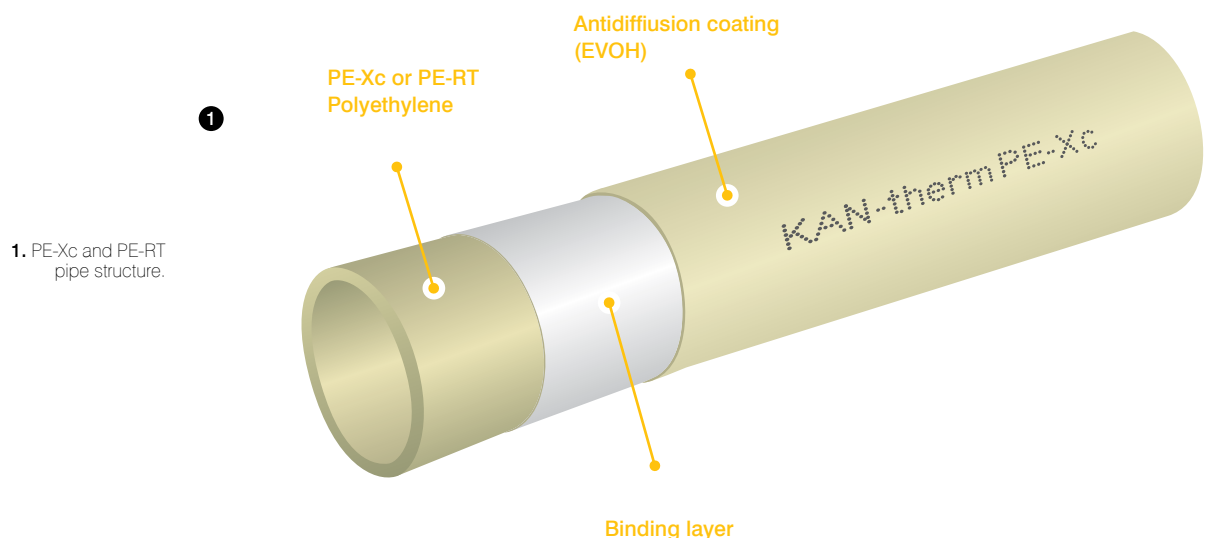

PE-Xc and PE-RT pipes in the KAN-therm Push System are offered in the 12-32mm diameter range and delivered in 25-200 m rolls.

DN	ex. diam. × wall thickn.	wall thickness	internal diameter	dimension series	mass by unit	number in roll	water capacity
	mm×mm	mm	mm		kg/m	m	l/m
with anti-diffusion coating							
12	12×2,0	2,0	8,0	2,5	0,071	200	0,050
14	14×2,0	2,0	10,0	3,0	0,085	200	0,079
16*	16×2,0	2,0	12,0	3,5	0,094	200	0,113
18*	18×2,0	2,0	14,0	4,0	0,113	200	0,154
18	18×2,5	2,5	13,0	3,10	0,125	200	0,133
25	25×3,5	3,5	18,0	3,07	0,247	50	0,254
32	32×4,4	4,4	23,2	3,14	0,390	25	0,423

* PE-Xc and PE-RT pipes of 16x2 and 18x2 in diameters are designed primarily for floor heating installations and heating installations in the manifold system (only screwed-in joints).

All PE-Xc and PE-RT pipes have the EVOH anti-diffusion coating securing the installation against oxygen diffusion to its interior.

Fittings

Reliability and compatibility

KAN-therm Push offers a complete range of fittings with matching slide-on rings.

All fittings are made of technologically advanced polymer PPSU or high quality brass.



Infallibility of a single joint determines the infallibility of the entire pipe system, and this effect is achieved through the application of the KAN-therm Push & Seal™ solution, self-sealing without the use of O-rings.

After sliding the pipe onto the fitting and then sliding the ring onto the joint, the system is sealed and prepared for taking the pressure test.

Fittings in the KAN-therm Push System have universal applications, which means that they can be used to joint PE-RT and PE-Xc polyethylene pipes and PE-Xc/Al/PE-HD Platinum multilayer pipes.

1. Cross-section of a Push joint.

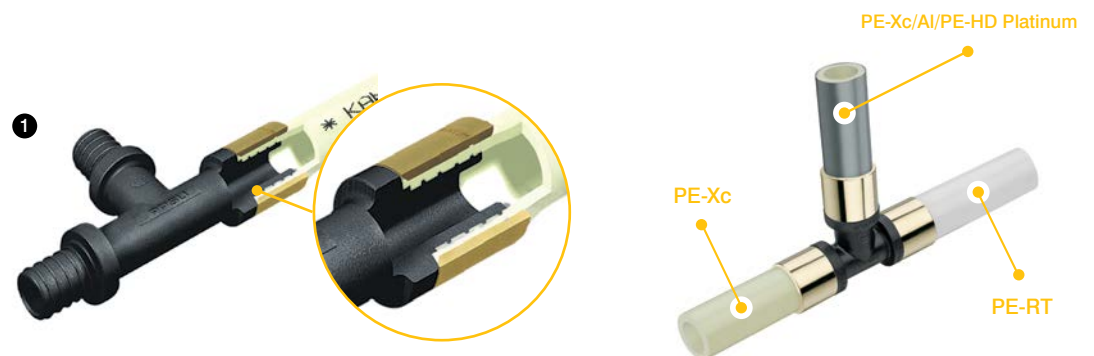

Durability

- All system elements are controlled in terms of quality assurance and durability at every stage of production.
- Before they are forwarded to the warehouse, finished elements undergo final, rigorous tests in KAN's laboratory.
- High quality and durability of the KAN-therm Push System was verified and confirmed with test KAN-therm T50™: a simulation of 50-years' installation use, carried out in KAN's international certifying laboratory.
- All system elements are manufactured in compliance with PN-EN ISO standards and hold certificates of the Polish Hygiene Institute.
- KAN-therm Push stands for reliability of correctly executed joints, safety during assembly and guaranteed long-term, undisturbed operation of the installation.



Tools

Professionalism

Apart from pipes and fittings, KAN-therm Push offers a wide range of professional, advanced tools for safe and secure performance of element joints. Equipment is offered as ready-to-use sets or as individual elements.

- **sets of electrical and battery-powered tools designed by Novopress, a leading European brand (1)**
- **Sets of pedal-operated hydraulic devices designed by KAN-therm (2)**
- **Sets of manual chain devices designed by KAN-therm (3)**





Faster, Comfortably, Safely

„One step” expanding heads

The new KAN-therm Push expander allows you to expand the pipe in one step. Currently it is the only tool available that allows for expanding PE-Xc and PE-RT pipes “at once”. This is possible due to the new and improved expanding head.

1. Innovative, 8-element body guarantees safe assembly without the risk of damaging the piping while expanding it “ONE STEP”.

2. New expanding head design allows for quick and safe assembly due to the ability to expand the end of the pipe in one cycle, using so called “ONE STEP expansion”.

3. New metal heat treatment technology greatly improves the element life.

4. Special plastic bag protects the heads from the environmental damage.

5. New, “ONE STEP” expanding heads and pipe press inserts (black and nickel plated) are marked with colors indicating the pipe diameter.

6. Special guide system inside the $\varnothing 32$ mm, expanding head protects it from damage resulting from exposure to strong forces.



Quick diameter recognition

All heads are marked with colored strips for easy identification and provided in a practical container. Pipe press inserts are also color coded according to their diameter. This method of identification makes the work easier for people responsible for installing pipes, selling them and people working at tool rental companies.



Easy and quick assembly

Joining KAN-therm Push System elements is performed using a simple, fast and, most of all, safe (no work is performed with open flames) technique of pushing a sliding ring (Push) onto the joint.

Non-O-ring and water-tight joints are achieved by sliding a brass ring onto the pipe-fitting joint using a manual, hydraulic or battery-powered press. Such joints do not require additional seals, such as sealing tape or tow.

1. Pipe cutting using pipe shears – cut perpendicularly to the pipe.

2. Slide the ring onto the pipe, with the chamfered edge directed towards the fitting.

3. Expand the pipe end using a manual or battery-powered expander.



4. Slide the fitting into the pipe until you reach the last notch.

5. Slide the ring using a manual, hydraulic pedal-operated or battery-powered press.

6. After positioning the ring, push it to the collar. The joint is ready for pressure test.



Highest quality guaranteed

The KAN-therm Push System stands for guaranteed, perfectly executed joints, safety and reliability of long-term, infallible operation of installations.

The production of system elements is controlled in the company's own, perfectly equipped research & development laboratory, and the results obtained are honored by leading European bodies.

As the entire activity of KAN, production is performed under the supervision of the ISO 9001 quality management system and is certified by the Lloyd's Register Quality Assurance Limited.

High quality of KAN-therm Push System elements is guaranteed by Polish and foreign certifying bodies:



Past projects

All our past projects performed in various sectors of the construction industry are the ideal confirmation of the highest quality of KAN-term Push products.

Although you can't see them at first glance, KAN-term installations have been successfully working in major housing estates, public buildings, single-family buildings, sports and recreation facilities, as well as industrial plants and factories for more than 20 years.

KAN-term is the perfect solution for new investments and renovated buildings, which is why you can also encounter it in historical and sacral buildings.

1. Hotel***** "Pyramid"
– Tychy, Poland.



2. Apartment building
"Parkowa Łazienki"
– Warsaw, Poland.



3. Rondo 1 Office Building
– Warsaw, Poland.

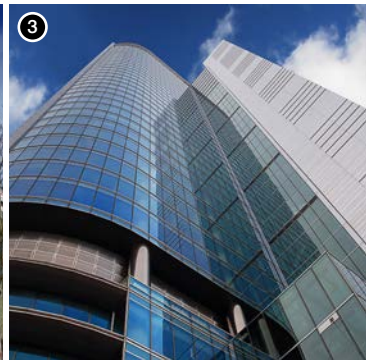

4. "Salwator City" housing estate
– Kraków, Poland.



5. District Court – Białystok, Poland.



6. Administrative building
– Poltava, Ukraine.



7. "Triumf" housing complex
– Kiev, Ukraine.



8. City clinic – Minsk, Belar.



9. "Tytan" entertainment and recreational
center – Minsk, Belarus.

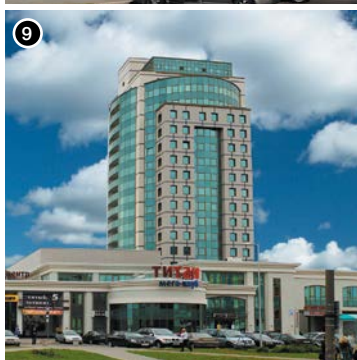

10. "Red Rose" Office center
– Moscow, Russia.

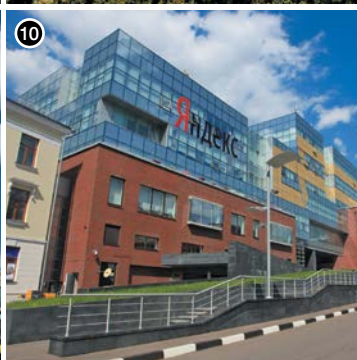

11. Moscow State University Library
– Moscow, Russ.



SYSTEM **KAN-therm**

Optimal, complete multipurpose installation system consisting of state of the art, mutually complementary technical solutions for pipe water distribution installations, heating installations, as well as technological and fire extinguishing installations.

It is the materialization of a vision of a universal system, the fruit of extensive experience, the passion of KAN's constructors, strict quality control of our materials and final products, and vast knowledge of the market of installations to meet the requirements of energy efficient, sustainable construction.

	Push Platinum	
	Push	
	Press LBP	
	PP	
	Steel	
	Inox	
	Sprinkler	
	Underfloor heating and automation	
	Football Stadium installations	
	Cabinets and manifolds	



KAN Sp. z o.o.
ul. Zdrojowa 51, 16-001 Białystok-Kleosin
tel. +48 85 74 99 200, fax +48 85 74 99 201
e-mail: kan@kan-therm.com

www.kan-therm.com